

ARMY CODE  
22260

AIR PUBLICATION  
AP 5046A(UH)

TRUCK, GENERAL SERVICE, 1 TONNE, 4 x 4 ROVER  
TRUCK, GENERAL SERVICE, FFR, 1 TONNE, 4 x 4 ROVER  
ISSUED JANUARY 1975

Amendment List No.4

November 1977

---

*NEW PAGES*

**Remove and replace pages:-**

85-86, 99-100 and 100A.

**AMENDMENT RECORD**

**Record** the incorporation  
of this amendment on the  
Amendment Record Sheet.

- (4) Check that the bolts securing the driving member to the front hubs are tight.
- (5) Check for signs of oil leakage from the differential and swivel pin housing filler and drain plugs, rectify if necessary.

## CHAPTER 9

### STEERING

#### RECIRCULATING BALL TYPE

##### INDEX

##### Description

Steering box lubrication .. ..	Fig. 69. Steering box oil filler plug.
Checks	
Steering ball joints	
Steering link adjustment .. ..	Fig. 70. Steering ball joint.
Front wheel alignment	
Steering relay unit .. ..	Fig. 71. Radiator grille removal. Fig. 72. Steering relay.

**156.** The steering unit is secured to a chassis bracket at the steering box and to a bracket on the dash panel at its upper end. It is of the recirculating ball type, the inner column having a spiral thread on which operates the main nut assembly.

The nut is free to move longitudinally in the steering box. The steering box is fitted with two replaceable bushes, in which operates the rocker shaft. The rocker shaft is attached to the main nut assembly by a fork and roller joint.

**157.** The 406 mm (16 in.) steering wheel is splined on to the inner column and secured by a nut.

**158.** A longitudinal steering tube, having left-hand and right-hand threaded ball joints, connects the drop arm to the upper lever of the steering relay unit mounted in the chassis cross-member just in front of the radiator. This relay unit incorporates spring loaded split 'Tufnol' cone bushes which damp the steering action and prevent minor road shocks being transmitted to the steering wheel.

**159.** The lower lever of the relay unit is connected to one steering arm by the drag link, which has left-hand and right-hand ball joints; the system is completed by the track rod connecting both steering arms, which is of a similar construction to the drag link.

### III

## User Servicing and Adjustments

### Steering box

#### Lubrication

160. The steering box oil level must be checked periodically. Fill if necessary to the level of the bottom threads of the filler plug hole (Fig 69). Access to the filler plug is gained from the front right hand wheel arch adjacent to the headlight.

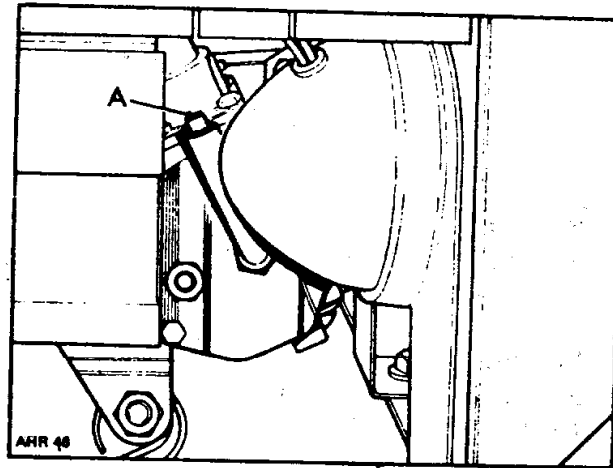

Fig. 69  
Steering box oil filler plug

A—Filler plug

#### Checks

161. The following points should be checked. Any leakage which persists after tightness checks and all defects noted must be reported:

- (1) Check for tightness the bolts securing steering box to the chassis bracket.
- (2) Check the side and bottom plates of the steering box for oil leakage and tightness.
- (3) Check that the drop arm, mounted on the steering box rocker shaft is secure.
- (4) Check steering column for wear or end-play. Adjust as necessary.
- (5) Check for tightness the bolts securing the steering column support bracket to dash panel.
- (6) Check steering wheel backlash; adjust as necessary.
- (7) Check ball joint for wear (see para. 162).
- (8) Check ball joint rubber boots ensuring that they have not become dislodged or damaged.

#### Steering ball joints

162. The steering joints have been designed in such a way as to retain the initial filling of grease for the normal life of the ball joints; however, this applies only if the rubber boot remains in position on the ball joint. See Fig. 70. The rubber boots should be inspected to

**Checks** (*To be carried out by a vehicle mechanic*)

**184.** The following points should be checked. All defects noted must be reported:

- (1) The clamp bolt (front) and U-bolt nuts (rear) Fig. 81 should be tight.
- (2) Examine the spring leaves for cracks or displacement and correct as necessary.
- (3) Check that leaf clips are tight.
- (4) Check that all damper retaining fixings are secure.
- (5) Check visually the spring bushes for excessive wear or damage. Rectify as necessary.
- (6) Check that the bump rubbers are secure and undamaged; replace as necessary.
- (7) Check hydraulic dampers for evidence of fluid leakage.

**Fig. 81**

Road springs

A—Nut for clamp bolt

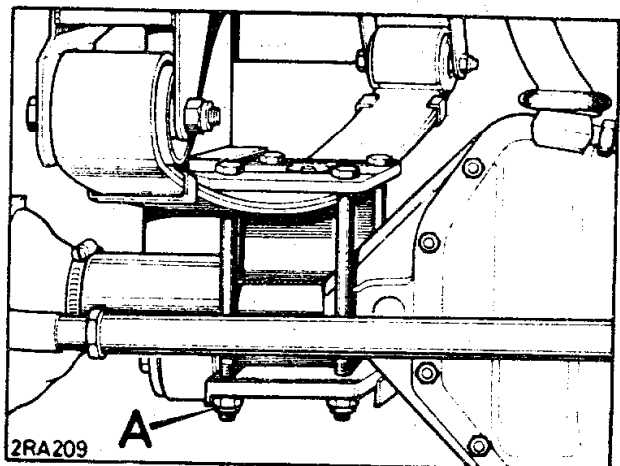

**CHAPTER 12**  
**WHEELS AND TYRES**

**WHEELS**  
**INDEX**

**Description**

Checks

Jacking the vehicle

Wheel changing

**Tyres**

Description

Factors affecting tyre life

Checks

Tyre pressures

Wheel and tyre balance

### III

### User Servicing and Adjustments

#### Description

**185.** Well-base type wheels are attached to the axle flange at the rear and to the hubs at the front by means of six studs and nuts.

#### Checks

**186.** The points detailed below should be checked. All defects noted must be reported:

- (1) Ensure that the wheel securing nuts are tight, tighten to a torque of between 10,3 and 11.7 kgf/m (75 and 85 lbf/ft).
- (2) Damage to road wheels.

#### Routine adjustments and servicing

##### Jacking the vehicle

Jacking procedure is as follows:

**Wheels should be checked in all circumstances.**

- (1) When positioning the jack below the axles the longest edge of the jack base should be at right angles to the axle, with the square drive of the jack towards either the rear of the vehicle for raising the rear axle or toward the front of the vehicle for raising the front axle.
- (2) Whenever possible site the vehicle on a hard level standing. If on soft ground use a flat load spreader to prevent the jack sinking.
- (3) On level or sloping ground, the gearbox differential lock should be engaged prior to stopping the engine and parking the vehicle.
- (4) The differential lock is only engaged if the warning light is illuminated with the ignition switched 'on'.
- (5) If the vehicle has been stationary prior to the jacking operation, the differential lock may not operate when the switch is raised. In this case it will be necessary to start the engine to create a vacuum and, perhaps drive the vehicle until the warning light is illuminated. Park the vehicle and switch 'off' the engine.
- (6) Apply the handbrake, continue the jacking procedure.

**Explanatory note:** Owing to the fact that the vehicle is fitted with a transmission handbrake, this will not be operative if the differential lock has not been engaged and one or both rear wheels are jacked up, whilst either gearbox is in neutral. Therefore, to obtain engine braking, both gearboxes should be engaged in 1st gear and 'low' transfer respectively.

The design of the transmission is such that jacking up the rear wheels, whilst on a slope, even with the differential lock engaged, could result in limited vehicle movement as a result of the 'back-lash' in the transmission.

The handbrake is operative within transmission back-lash limits, if the rear wheels are to stay on the ground and one or both front wheels are jacked up, irrespective of the gearbox differential lock engagement. **Therefore always chock wheels.**

(

.

.

.

(